

Monoblock Directional Control Valve

MCD20 and MCD50 Series



Features

- MCD20 and MCD50 Series are monoblock directional control valves with parallel circuits. The standard valve comes with an adjustable main relief valve, check valve, and 4 mounting holes for standard and optional mounting. The carry over circuit, spool types, spool controls, and other options are available.
- The compact casting is made of high strength cast iron. The spools are made of hardened and tempered steel.



Specification

	Nominal Flow <i>L/min (USgpm)</i>	Max. Pressure <i>bar (psi)</i>
MCD20	45 (12)	210 (3000)
MCD50	70 (18)	210 (3000)
*MCD100/3	100 (26)	350 (5100)

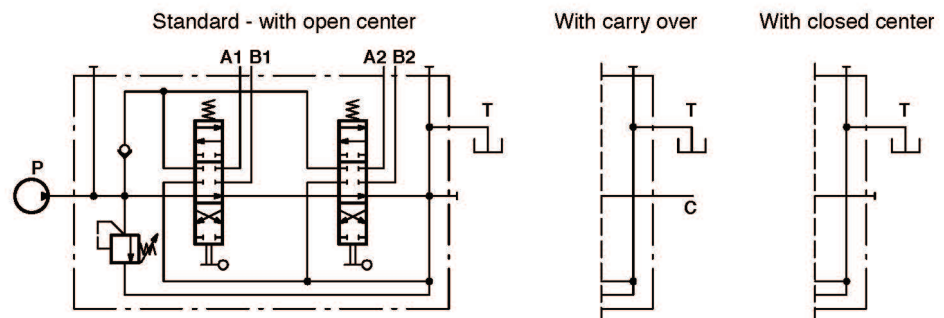

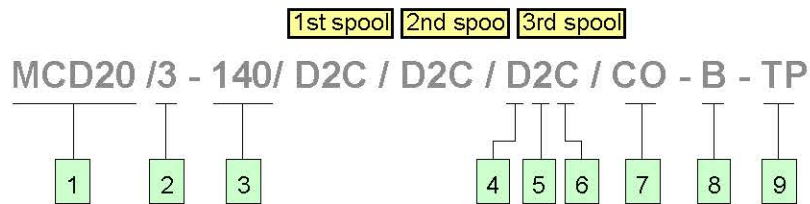

1 Model
MCD20, MCD50, MCD100

2 Number of Spool
1 - 3

3 Relief Valve Setting
no code - 210 bar
- 140 bar

4 Spool Control
no code - Spring return to center
D - Detent in three positions
I - Detent in two positions
O - Detent out two positions

5 Spool Type
no code or 1 - Double acting, 3 position with A and B
(Type.1) closed in center (Cylinder spool)
(Type.2) 2 - Double acting, 3 position with A and B
to tank in center (Motor spool)
(Type.3) 3 - Single acting on A, 3 position B plugged
(Type.4) 4 - Single acting on B, 3 position A plugged

6 Service Valve (MCD20 only)
no code - Without valve
P - Without valve, but with pre-arranged holes
C - With pilot operated check valves on port A and B
*With Service Valve, the main valve body will come without Port P
and T on top and Port A and B can be BSPT 3/8" only, but Port A
and B on check valve can be any threads as specified in Ordering Code

7 Circuit Option
no code or OC - With open center plug
CO - With carry over plug
CC - With closed center plug

8 Port Thread

MCD20

Code	Thread	Port A-B	Port P	Port T	Port CO
no code	BSP	3/8"	3/8"	3/8"	3/8"
B	BSP	1/2"	1/2"	1/2"	3/8"
S	SAE	SAE 8	SAE 10	SAE 10	SAE 8

MCD50

Code	Thread	Port A-B	Port P	Port T	Port CO
no code	BSP	1/2"	1/2"	3/4"	1/2"
B	BSP	3/4"	3/4"	3/4"	1/2"
S	SAE	SAE 10	SAE 12	SAE 12	SAE 12

*Only for MCD100/3

no code	BSP	3/4"	3/4"	3/4"	3/4"
---------	-----	------	------	------	------

9 Optional Port Connection
no code - Port P and T at side with optional
Port P and T plugged on top
TP - Port P and T on top with optional
Port P and T plugged at side

MCD20/1

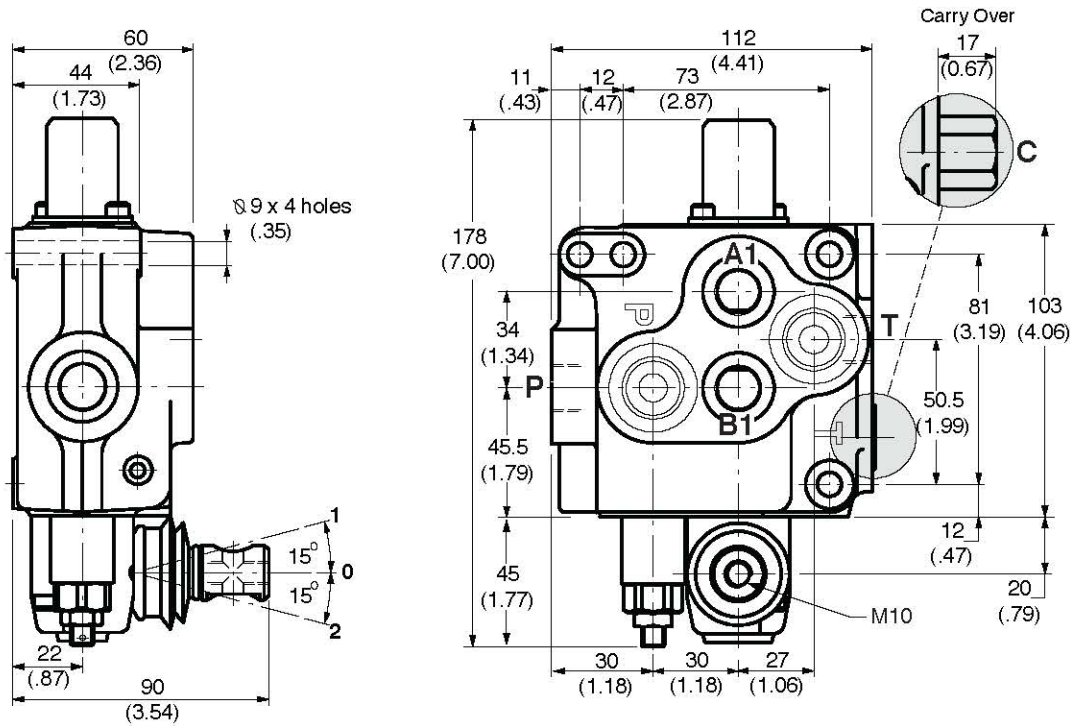

Weight: 3.6 kg (7.9 lb)

MCD20/2

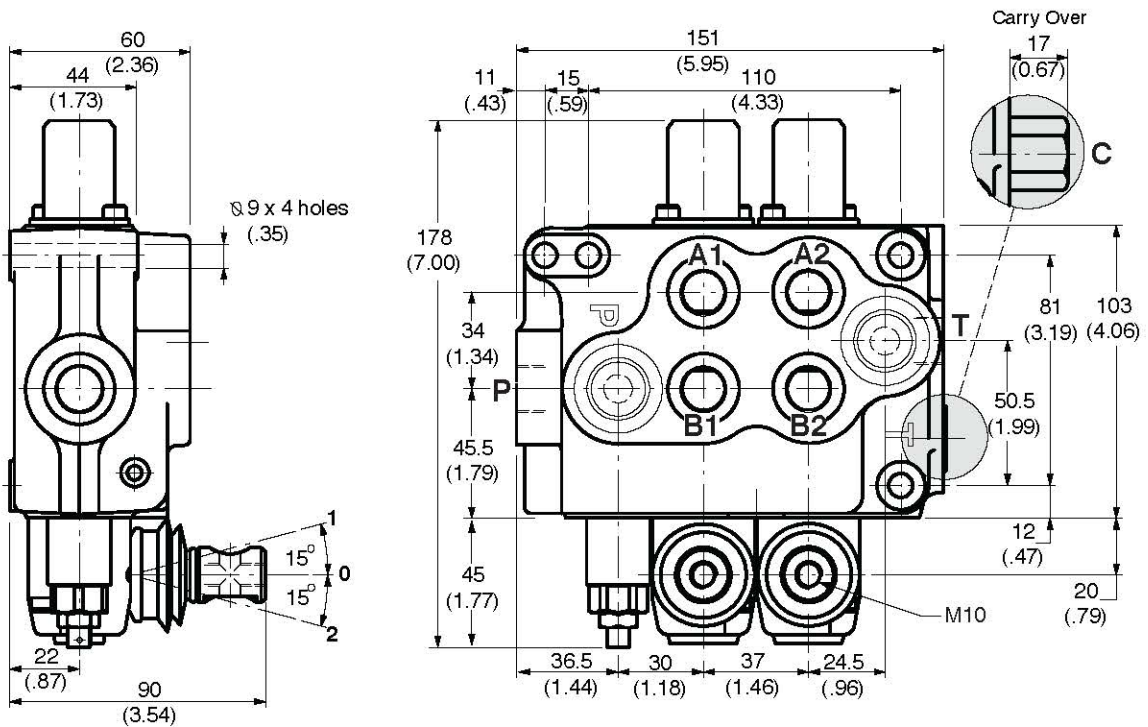

Weight: 5.1 kg (11.2 lb)

MCD50/1

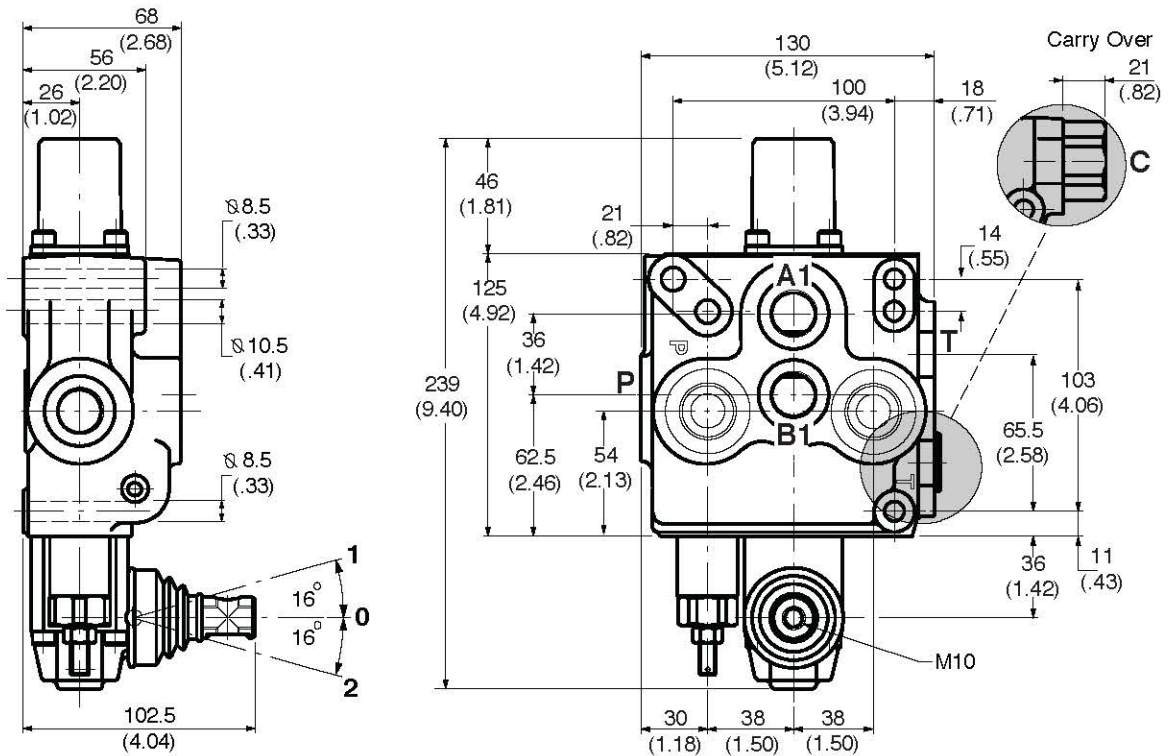

Weight: 5.5 kg (12.1 lb)

MCD50/2

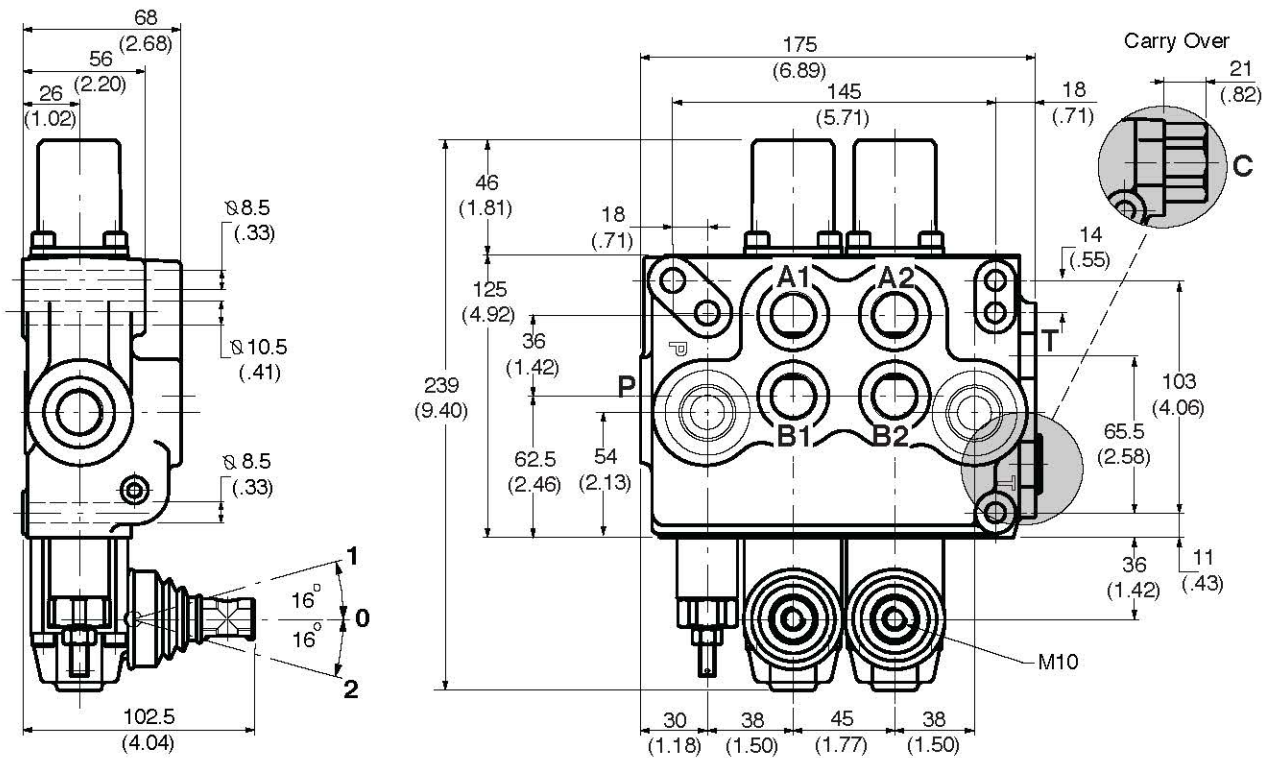

Weight: 8.5 kg (18.7 lb)

MCD100/3

Standard working conditions

Max. recommended flow	100 l/min	(26 GPM)
Max. pressure	350 bar	(5100 PSI)
Max. backpressure	80 bar	(1160 PSI)

Thread	Port A-B	Port P	Port T	Carry Over
BSP	3/4"	3/4"	3/4"	3/4"
SAE	SAE12	SAE12	SAE12	SAE10

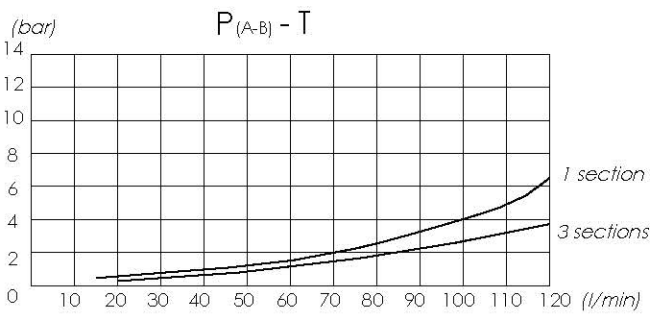
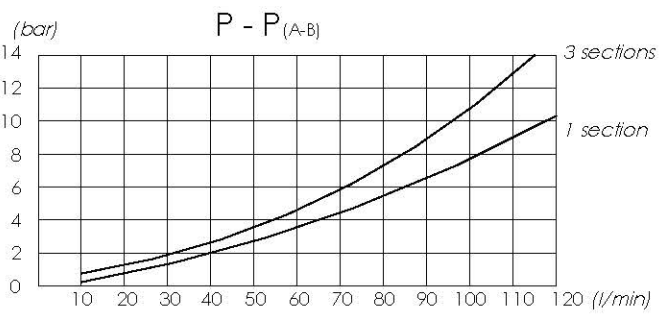
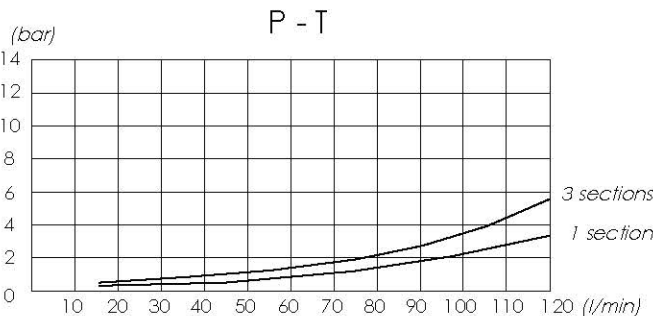
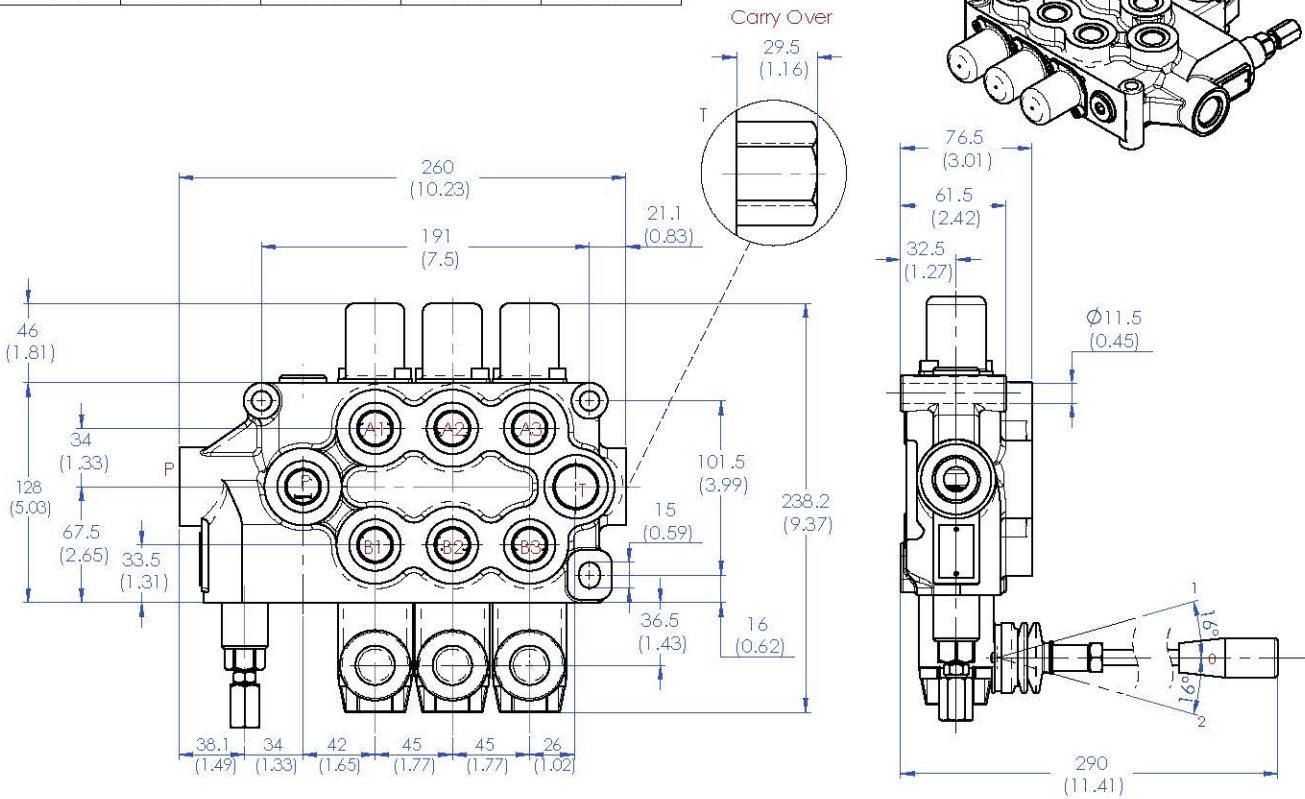
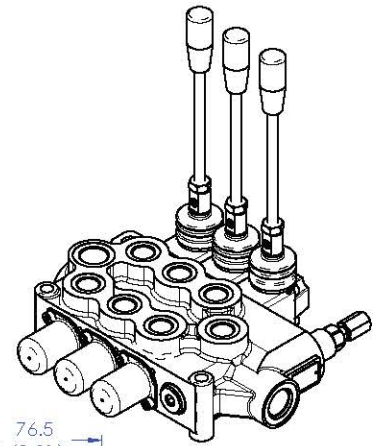

PRESSURE DROP

Weight: 11.8 kg (26.0 lb)

Sectional Directional Control Valve

MCD10 and MCD25 Series



Features

MCD10 and MCD25 are modular sectional directional control valves, capable of working with 90 liters / min (MCD10) and 380 liters/min at 350 bar operating pressure. Both valves are highly flexible and easily adaptable to most application. A wide range of options is available to cater widest range of application.

Specification

Nominal Flow	80 L/min (21 USgpm)
Max. Pressure	210 bar (3000 psi)
Port A-B	BSP 1/2", SAE8, BSP 3/4"
Port P	BSP 1/2", SAE10, BSP 3/4"
Port T	BSP 3/4", SAE10, BSP 3/4"

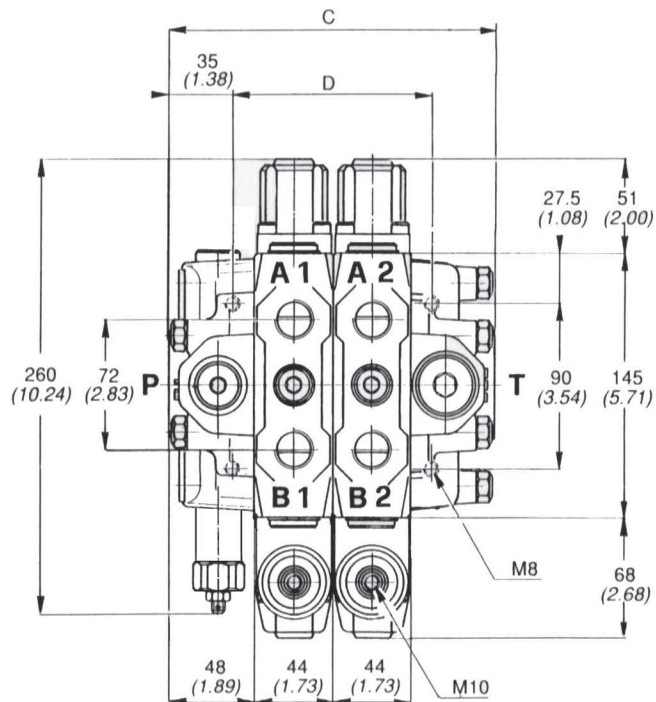
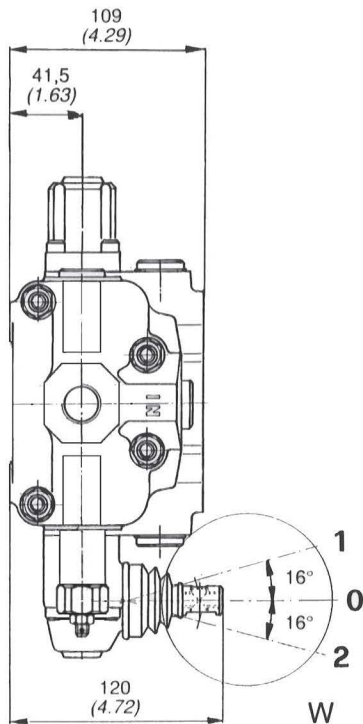

	C		D		Weight	
	mm	inch	mm	inch	kg	lb
MCD 10/1	144	5.67	70	2.76	10.2	22.4
MCD 10/2	188	7.40	114	4.49	14.9	32.8
MCD 10/3	232	9.13	158	6.22	19.6	43.1
MCD 10/4	276	10.87	202	7.95	24.3	53.5
MCD 10/5	320	12.60	246	9.69	29.0	63.8
MCD 10/6	364	14.33	290	11.42	33.7	74.1
MCD 10/7	408	16.06	334	13.15	38.4	84.5
MCD 10/8	452	17.80	378	14.88	43.1	94.8
MCD 10/9	496	19.53	422	16.61	47.8	105.2
MCD 10/10	540	21.26	466	18.35	52.5	115.5



1 Model
MCD10, MCD25

2 Number of Spool
1 - 12

3 Relief Valve Setting (Inlet cover)
no code - 210 bar
- 140 bar

4 Spool Control
no code - Spring return to center
D - Detent in three positions
I - Detent in two positions
O - Detent out two positions

5 Spool Type
no code or 1 - Double acting, 3 position with A and B (Type.1) closed in center (Cylinder spool)
(Type.2) 2 - Double acting, 3 position with A and B to tank in center (Motor spool)
(Type.3) 3 - Single acting on A, 3 position B plugged
(Type.4) 4 - Single acting on B, 3 position A plugged

6 Service Valve (Intermediate section)
no code - Without valve
P - Without valve, but with pre-arranged holes
A - With Anti-cavitation valves on port A and B
W - With Work port relief valves on port A and B
AW - With Anti-cavitation valve on port A or B and with Work port relief valve on port A or B

7 Circuit Option (Outlet cover)
no code or OC - With open center plug
CO - With carry over plug
CC - With closed center plug

8 Port Connection
T - Threaded Port

MCD10

Code	Thread	Port A-B	Port P	Port T	Port CO
no code	BSP	1/2"	1/2"	3/4"	3/4"
B	BSP	3/4"	3/4"	3/4"	3/4"
S	SAE	SAE 8	SAE 10	SAE 10	SAE 10

MCD25

Code	Thread	Port A-B	Port P	Port T	Port CO
no code	BSP	1"1/4	1"1/4	1"1/2	1"1/2
B	BSP	1"1/2	1"1/2	1"1/2	1"1/2
S	SAE	SAE 20	SAE 20	SAE 20	SAE 20

F - Flange Connection (MCD25 only)

no code or 1.25 - SAE port 1"1/4-11.5 NPTF
1.50 - SAE port 1"1/2-11.5 NPTF

9 Optional Port Connection

MCD10

no code - Port P and T at side with optional
Port P and T plugged on top
TP - Port P and T on top with optional
Port P and T plugged at side

MCD25

no code - Port P and T on top without optional
TP - Port P and T on top with optional
Port P and T plugged at side
SP - Port P and T at side with optional
Port P and T plugged on top

MCD25

Standard working conditions

Max. recommended flow	380 l/min	(100 GPM)
Max. pressure	350 bar	(5100 PSI)
Max. backpressure	20 bar	(290 PSI)
Tie rod tightening torque	110 Nm	(81.13 lbf·ft)

Installation Dimensions mm. (inch).

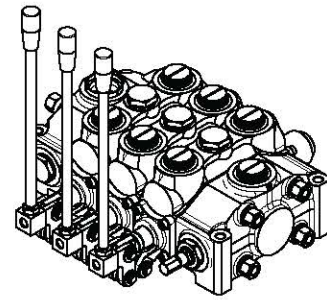

AVAILABLE THREADS		
PORTS	BSP	SAE
A-B	G 1 1/4	SAE 20
P	G 1 1/4	SAE 20
T	G 1 1/2	SAE 20
Carry-over	G 1 1/2	SAE 20

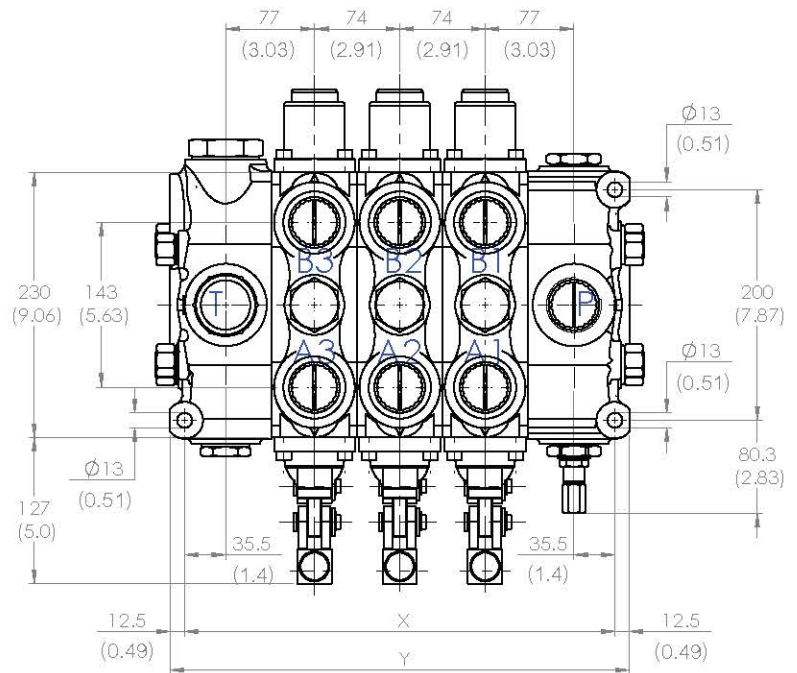
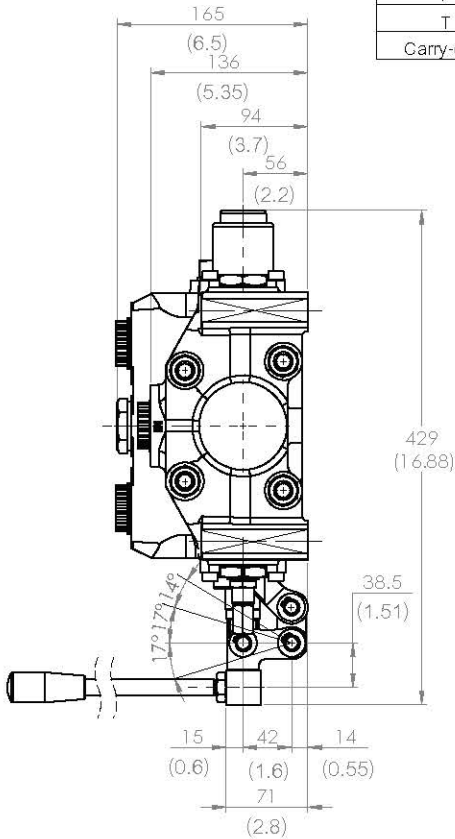

Variable Dimension

Type	/1	/2	/3	/4	/5	/6	/7	/8	/9	/10	/11	/12
X(mm)	225	299	373	447	521	595	669	743	817	891	965	1039
X(in)	8.9	11.8	14.7	17.6	20.5	23.4	25.6	28.5	31.4	34.3	37.2	40.1
Y(mm)	250	324	398	472	546	620	694	768	842	916	990	1064
Y(in)	9.84	12.8	15.7	18.6	21.5	24.4	27.3	30.2	33.1	36.1	38.9	41.8

Weights

Type	/1	/2	/3	/4	/5	/6	/7	/8	/9	/10	/11	/12
Kg.	40.4	55.8	71.2	86.6	102	117.4	132.8	148.2	163.6	179	194.4	209.8
lb	89.06	123.0	156.9	190.9	224.8	258.8	292.7	326.7	360.6	394.6	428.5	462.5

Pressure drop (P - T)

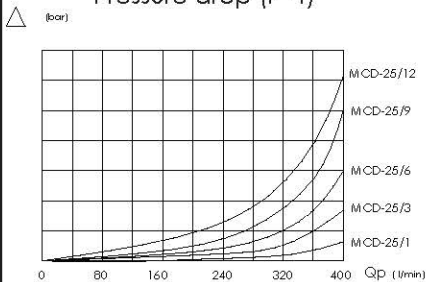

Pressure drop (P - A/B)

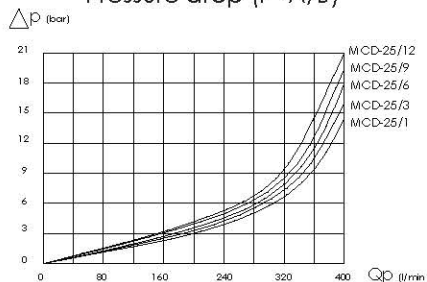

Pressure drop (A/B - T)

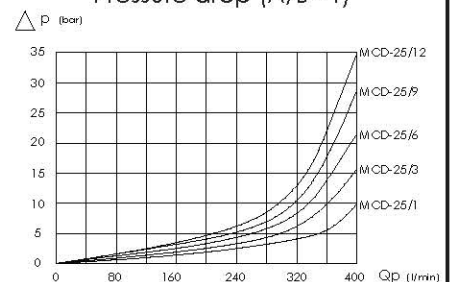

Compact Monoblock Directional Control Valve

MB20 Series



Features

MB20 Series is a monoblock directional control valves entirely developed to perform equivalent basic function as MCD20. MB20 is very compact in size yet comes with all standard feature such as adjustable main relief valve, check valve, carry over circuit, and 2 mounting holes.

MB20 made of high strength cast iron. The spools are made of hardened and tempered steel with varieties of spool types and controls.

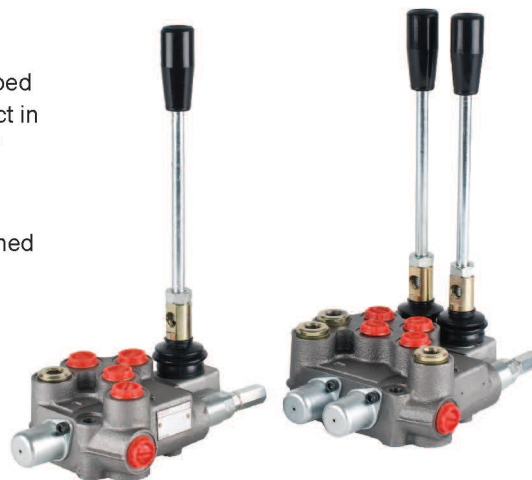

Specification

	Nominal Flow L/min(USgpm)	Max. Pressure bar (psi)
MB20	45(12)	210(3000)

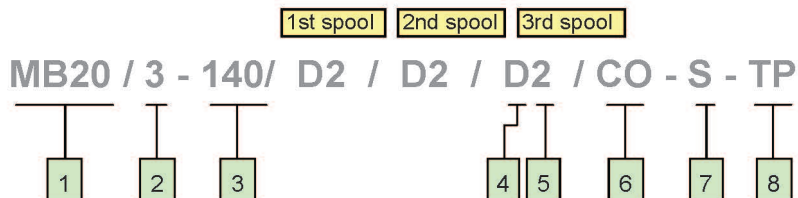

- 1 Model
MB20
- 2 Number of Spool
1 - 3
- 3 Relief Valve Setting
no code - 210 bar
- 140 bar
- 4 Spool Control
no code - Spring return to center
D - Detent in three positions
I - Detent in two positions
O - Detent out two positions
- 5 Spool Type
no code or 1 - Double acting, 3 position with A and B
(Type.1) closed in center (Cylinder spool)
(Type.2) 2 - Double acting, 3 position with A and B
to tank in center (Motor spool)
(Type.3) 3 - Single acting on A, 3 position B plugged
(Type.4) 4 - Single acting on B, 3 position A plugged
- 6 Circuit Option
no code or OC - With open center plug
CO - With carry over plug
CC - With closed center plug
- 7 Port Thread

Code	Thread	Port A-B	Port P	Port T	Port CO
no code	BSP	3/8"	3/8"	3/8"	3/8"
S	SAE	SAE 8	SAE 8	SAE 8	SAE 8
- 8 Optional Port Connection
no code - Port P and T at side with optional
Port P and T plugged on top
TP - Port P and T on top with optional
Port P and T plugged at side

MB20/1

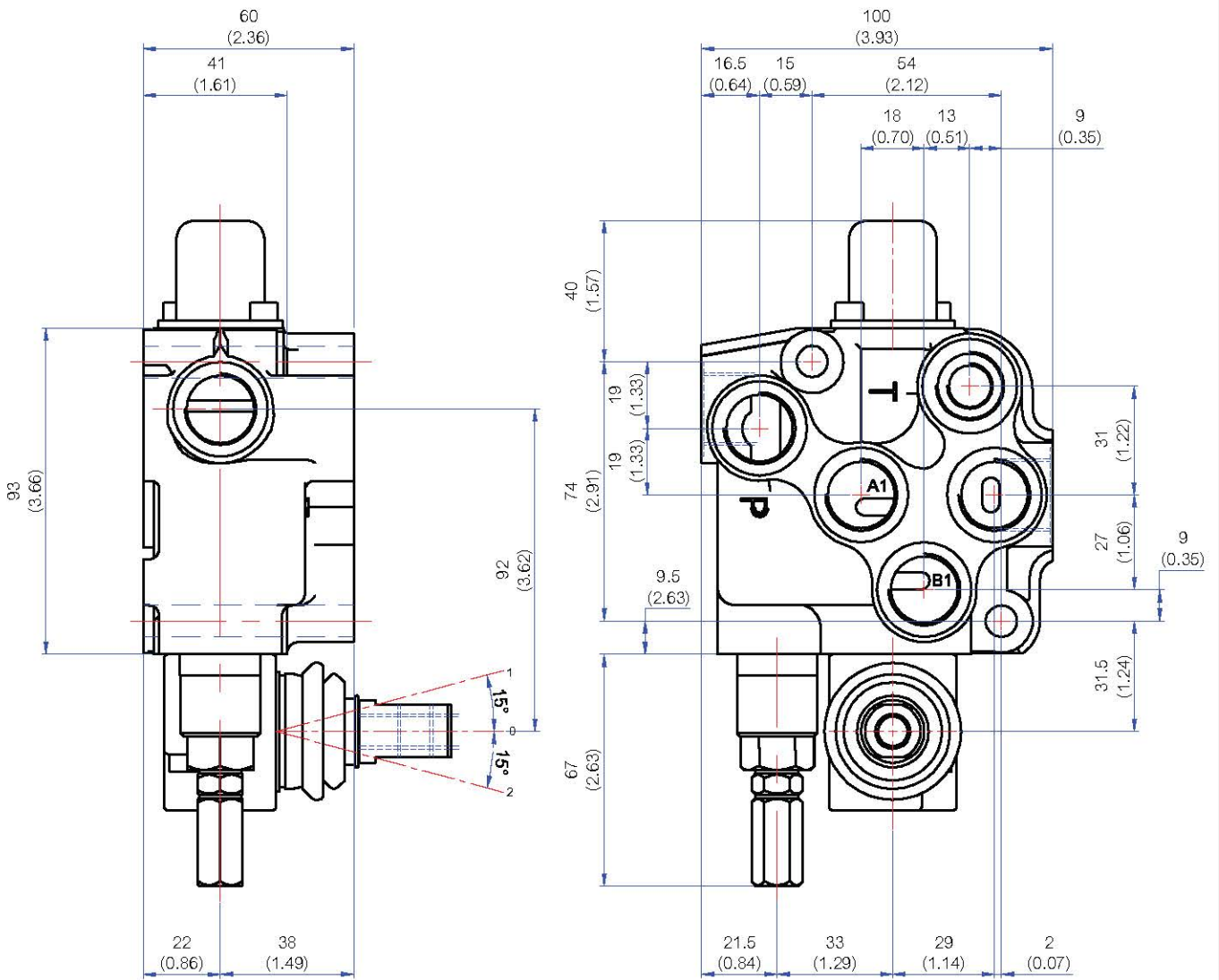

PRESSURE DROP

50° C-122°F 33mm²/s-150sus

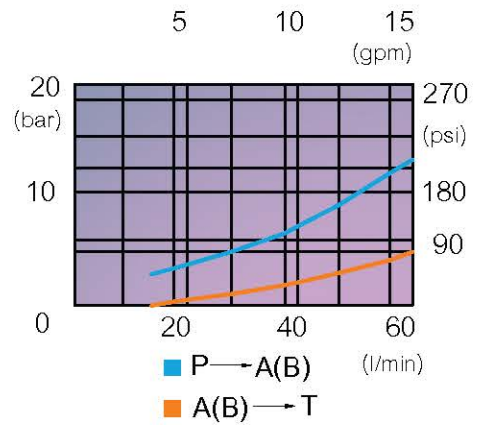
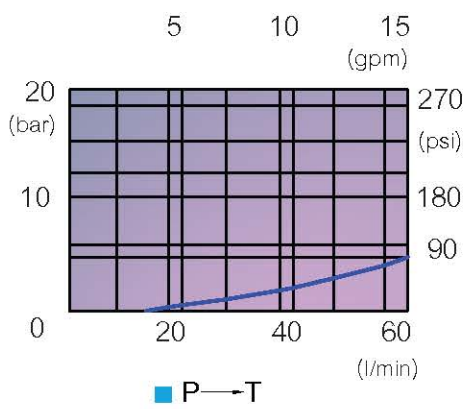

Weight: 3.0 kg (6.61 lb)

MB20/2

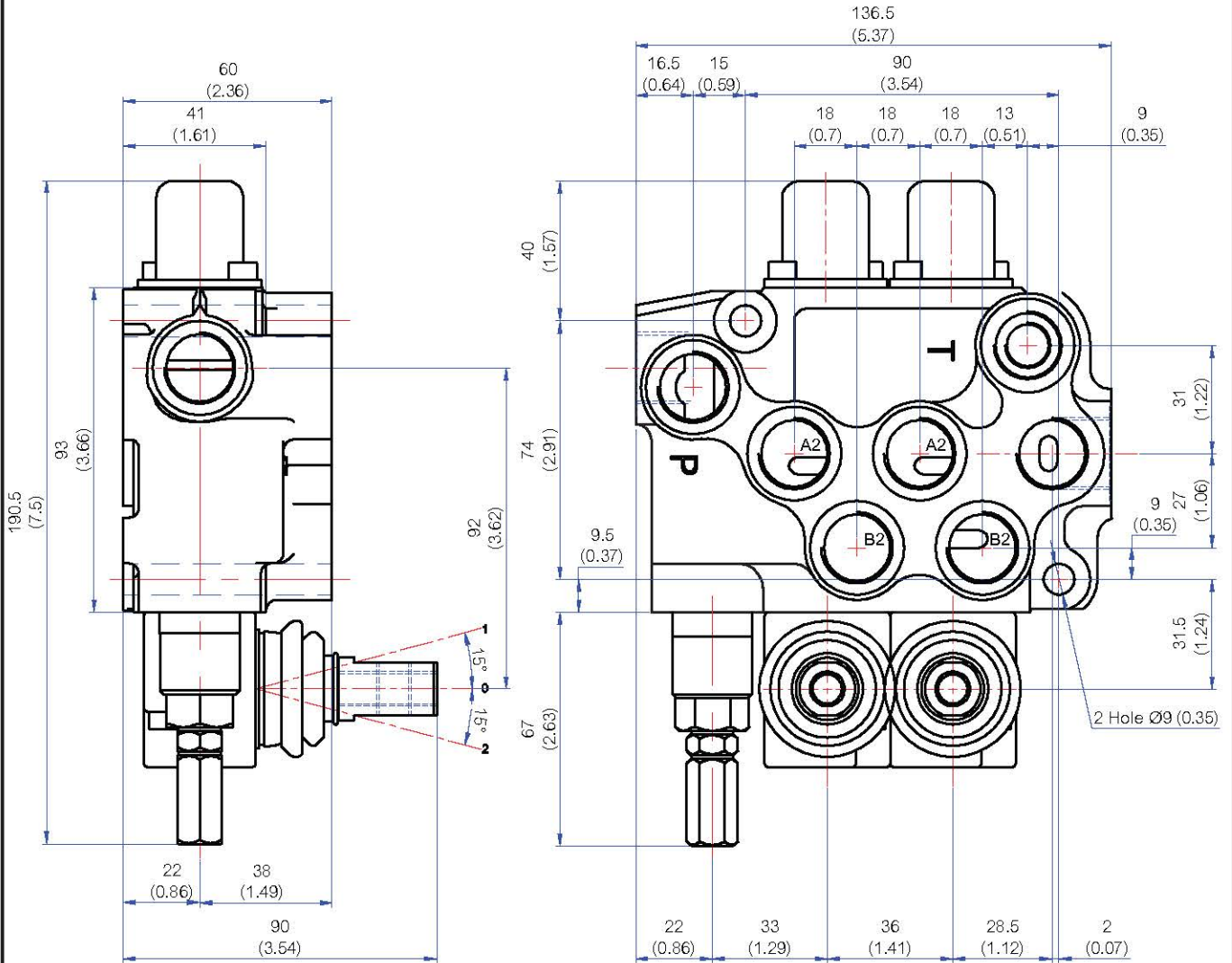

PRESSURE DROP

50° C-122°F 33mm/s-150sus

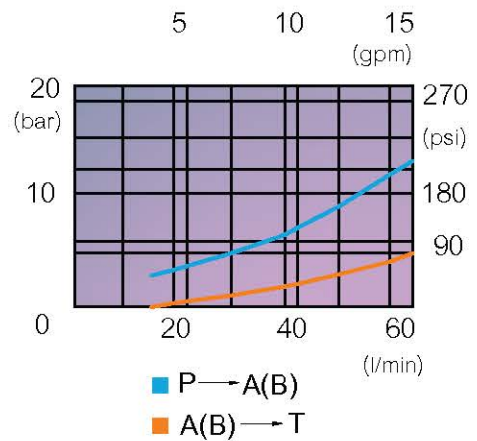
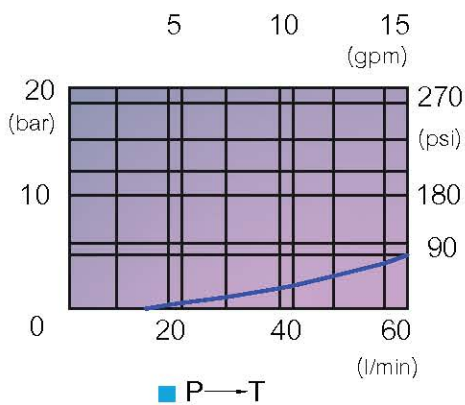

Weight: 4.5 kg (9.92 lb)