

**Features:**

- Sandwich plate valve
- 4 pressure ranges
- 5 circuit options
- With one or two pressure relief cartridges
- 4 adjustment elements:
  - Rotary knob
  - Sleeve with hexagon and protective cap
  - Lockable rotary knob with scale
  - Lockable rotary knob
- Porting pattern to DIN 24 340, form A,ISO 4401 and CETOP-RP 121H



**Functional, section**

Pressure relief valve types ZDB and Z2DB are pilot operated and are of sandwich plate design.

They are used to limit the pressure within a hydraulic system.

They basically consist of the housing (7), together with one or two pressure relief valve cartridges.

The system pressure is set by means of adjustment element (4).

At rest, the valve is closed. Pressure in port A acts on the spool (1). At the same time pressure passes through orifice (2) on to the spring loaded side of spool (1) and via orifice (3) to the pilot poppet (6). If the pressure in port A rises above the value set on spring (5), the pilot poppet (6) opens. Fluid can now flow from the spring loaded side of spool (1), orifice (3), and channel (8) into port T. The resulting pressure drop then moves spool (1), causing this to open connection A to T, while the pressure set at spring (5) is maintained.

Pilot oil from the two spring chambers return externally to tank via port T.

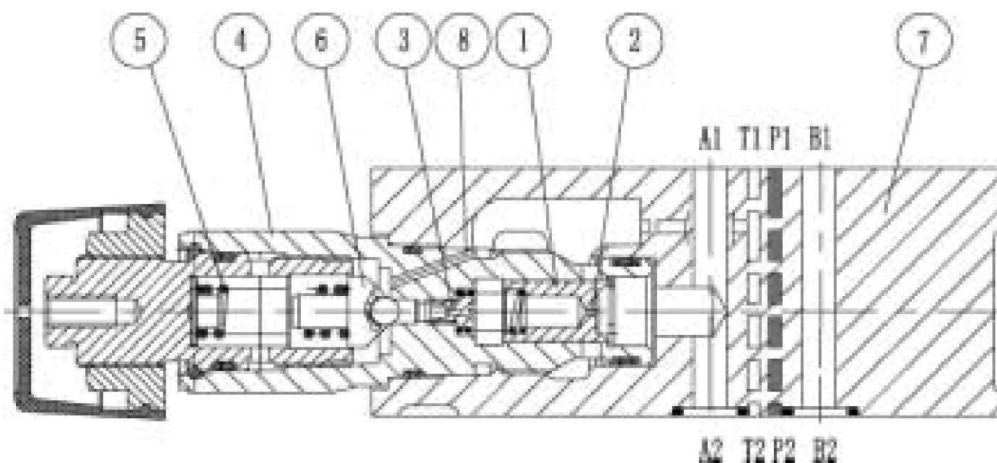

Type ZDB 6 VA2 - 40B/..

## Ordering code

Z      DB 6      -      - 40      \*

Sandwich plate = Z

Further details in clear text

Only applies to models VC and VD:

With 1 pressure relief valve cartridges = no code

With 2 pressure relief valve cartridges = 2

No code = mineral oils

V = phosphate ester

50 = Pressure adjustable up to 5 MPa

100 = Pressure adjustable up to 10 MPa

200 = Pressure adjustable up to 20 MPa

315 = Pressure adjustable up to 31.5 MPa

Pressure relief valve = DB

Nominal size 6 = 6

40= Series 40 to 49  
(40 to 49 = unchanged installation and connection dimensions)

Relief function form:

A → T = VA

P → T = VP

B → T = VB

A → T and B → T = VC

A → B and B → A = VD

Adjustment element

1 = Rotary knob

2 = Sleeve with hexagon and protective cap

3 = Lockable rotary knob with scale

7 = Rotary knob with scale

## Symbols

Type ZDB 6 VA ..

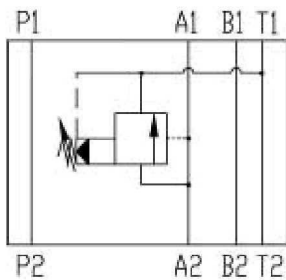

Type ZDB 6 VB ..

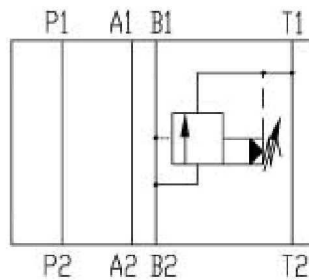

Type ZDB 6 VP ..

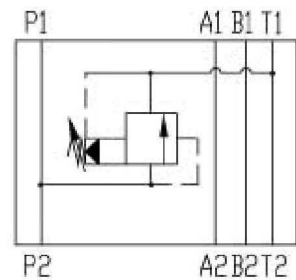

Type Z2DB 6 VC ..

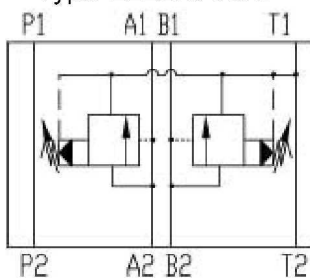

Type Z2DB 6 VD ..

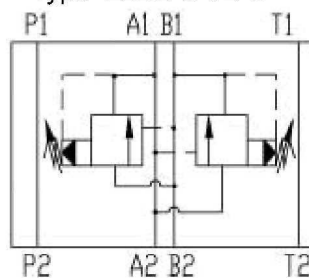

**Technical data** (For applications outside these parameters, please consult us!)

Pressure fluid	Mineral oil (for NBR seal), or phosphate ester (for FPM seal)	
Pressure fluid - temperature range (°C)	-30~+80	
Viscosity range (mm <sup>2</sup> /s)	10~800	
Degree of fluid contamination	Maximum permissible degree of contamination of the fluid is to NAS 1638, class 9. $\beta_{10} \geq 75$	
Operating pressure, max. (MPa)	up to 31.5	
Pressure adjustable, max. setting (MPa)	up to 5, to 10, to 20, to 31.5	
Flow, max. (L/min)	up to 60	
Weight	Type ZDB 6 (Kg)	approx. 1
	Type Z2DB 6 (Kg)	approx. 1.2

**Characteristic curves** (measured at  $v = 41 \text{ mm}^2/\text{s}$  and  $t = 50^\circ\text{C}$ )

$P_E$  - Q characteristic curve

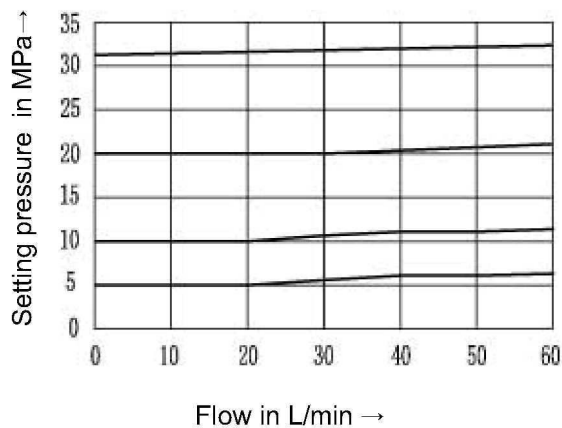

$P_{Emin}$  - Q characteristic

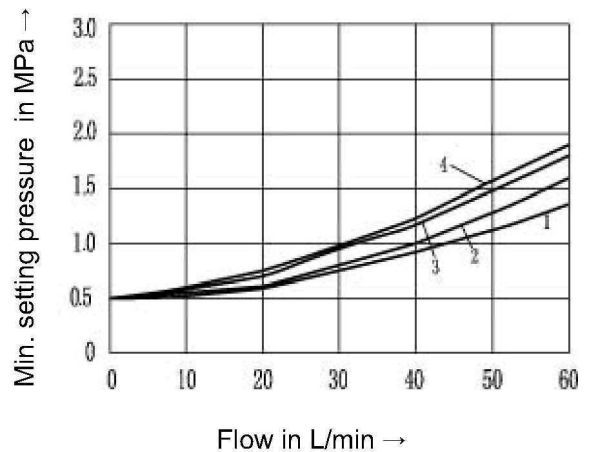

- |               |                    |
|---------------|--------------------|
| 1 VD (A to B) | 3 VB , VC          |
| 2 VA          | 4 VP , VD (B to A) |

Type ZDB6 VA..

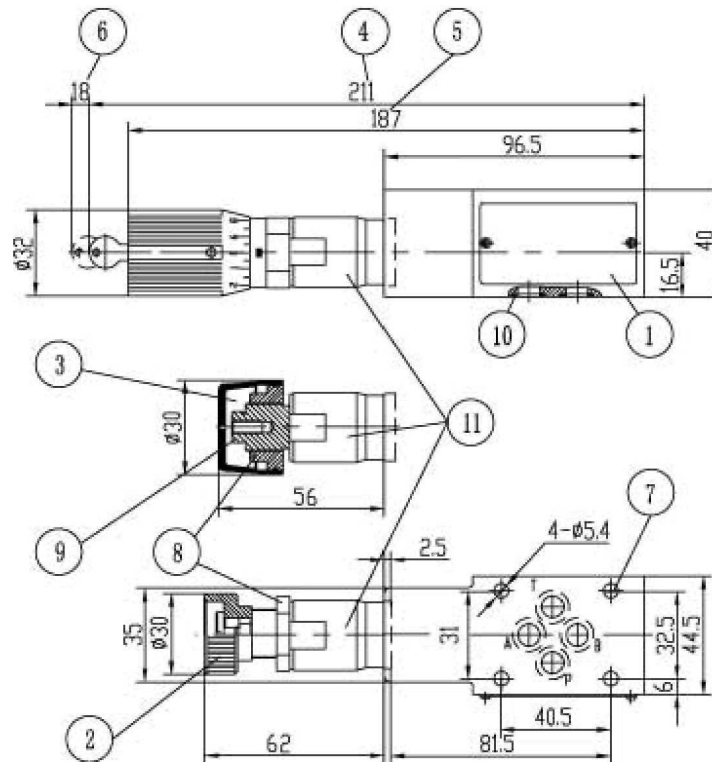

Type ZDB6 VB.. and ZDB6 VP..

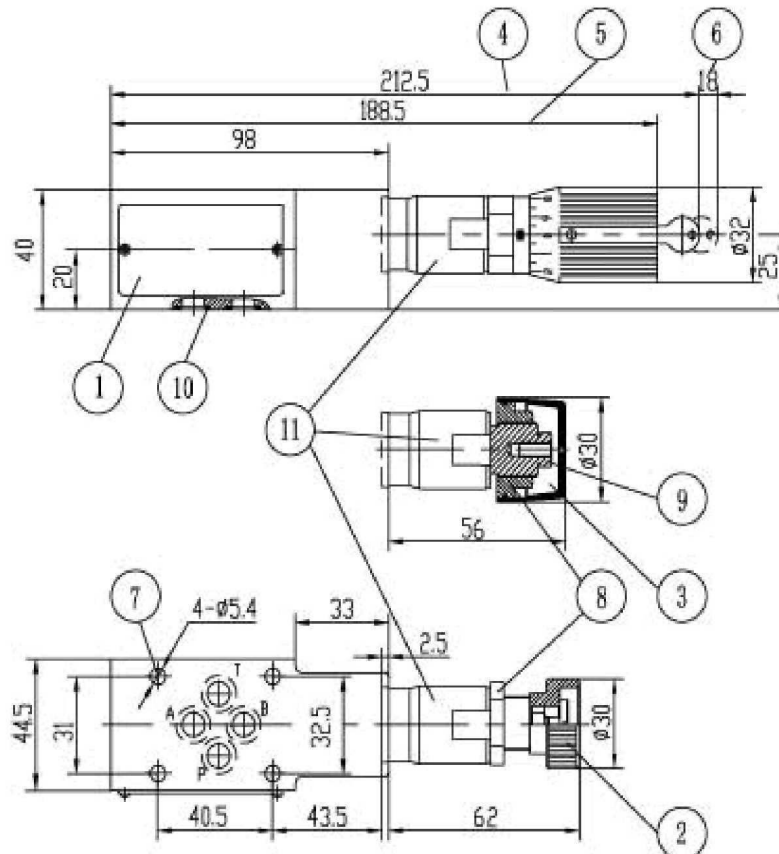

Type Z2DB6 VC..and Z2DB6 VD..

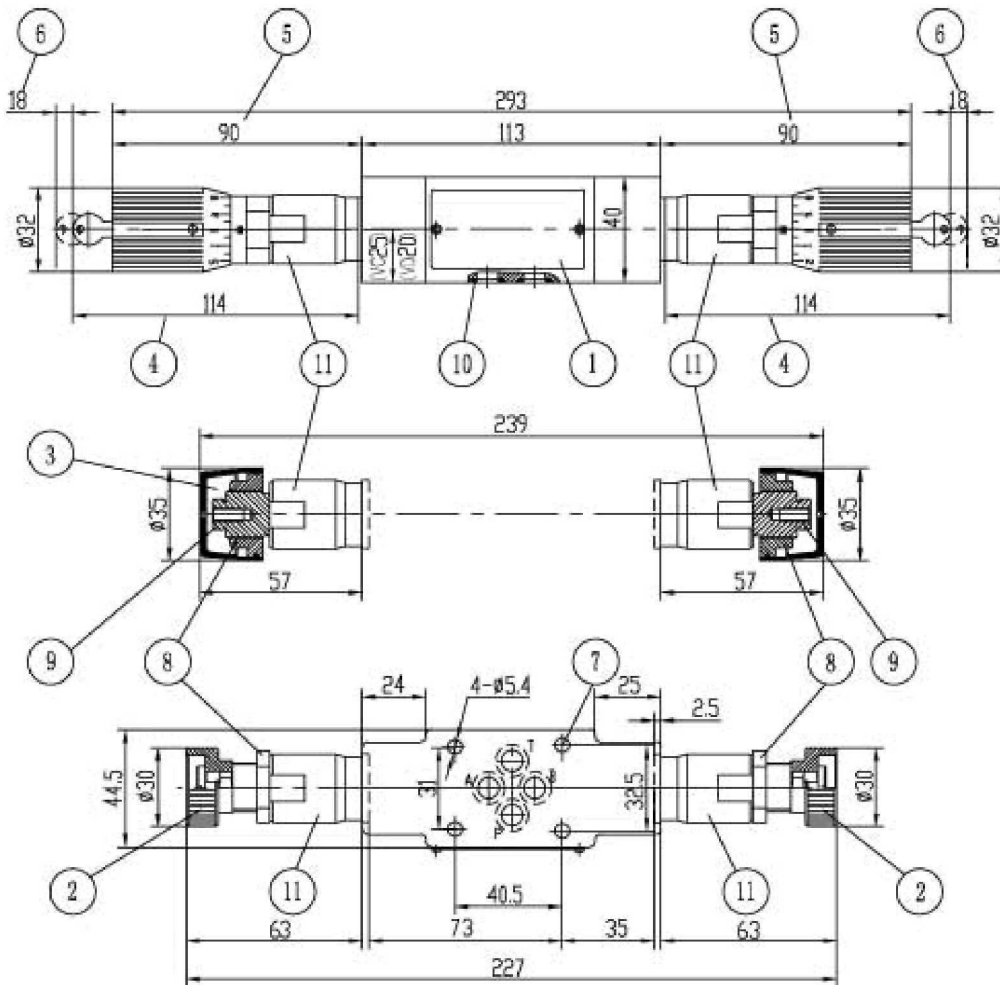

- 1 Nameplate
  - 2 Adjustment element 1
  - 3 Adjustment element 2
  - 4 Adjustment element 3
  - 5 Adjustment element 7
  - 6 Space required to remove key
  - 7 Valve fixing screw holes
  - 8 Lock nut 24 A/F
  - 9 Hexagon 10 A/F
  - 10 O-ring 9.25 x 1.78 for ports A2, B2, P2, T2
  - 11 Hexagon 24 A/F
- Tightening torque  $M_A = 50 \text{ Nm}$

Required surface finish of mating piece

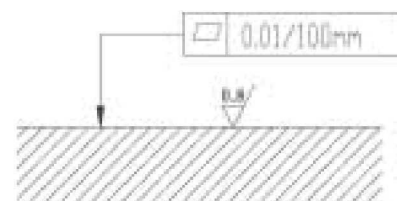

## NOTICE

1. The fluid must be filtered. Minimum filter fineness is 20  $\mu\text{m}$ .
2. The tank must be sealing up and an air filter must be installed on air entrance.
3. Products without subplate when leaving factory, if need them, please ordering specially.
4. Valve fixing screws must be high intensity level (class 10.9). Please select and use them according to the parameter listed in the sample book.
5. Roughness of surface linked with the valve is required to  $0.8 \sqrt{\text{R}}$ .
6. Surface finish of mating piece is required to 0.01/100mm.